

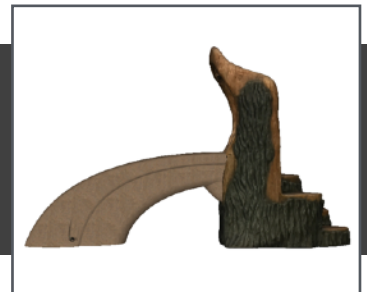

A play system designed with the pint sized players in mind. Our Oak Landing provides hours of climbing and sliding fun.

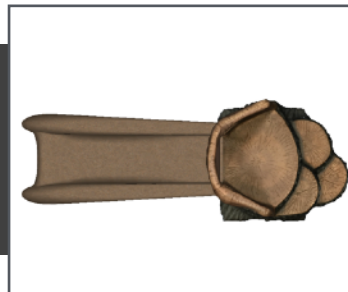

**Oak Landing  
1000226**

L: 7'-1" x W: 2'-9" x H: 4'-2"  
700 LBS

~ Dimensions and weights are approximate ~  
~ Heights shown from top of surfacing ~  
**User Group Age: 2-5**

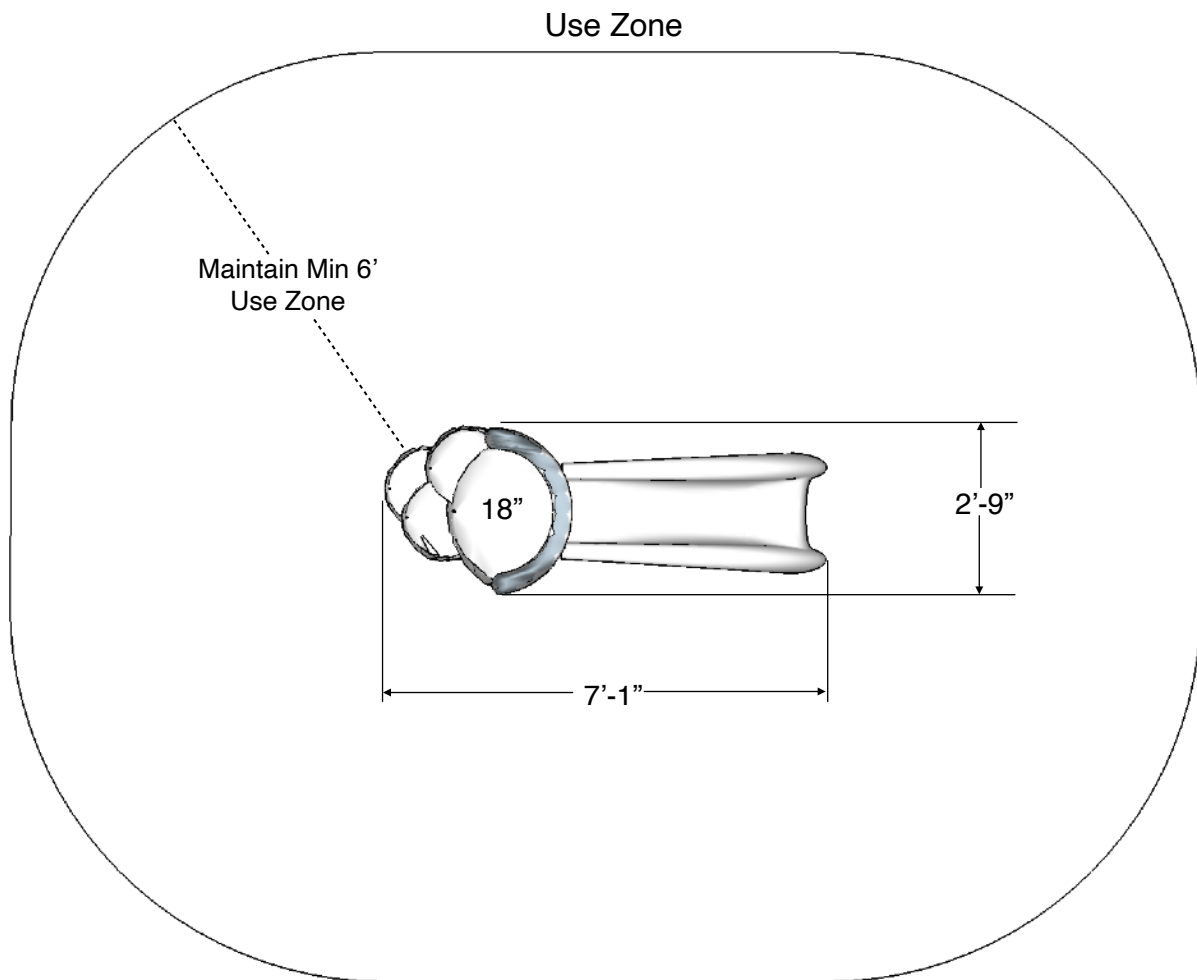

Product: 1000226

**Included Items:**

Item	Description	Quantity
Oak Landing	Play Equipment	1
Anchor Bolt 1/2" x 3"	Mounting Hardware	4-In-ground, 6-Surface mount
Hardware Kit	Assembly Hardware	1

**In-Ground**

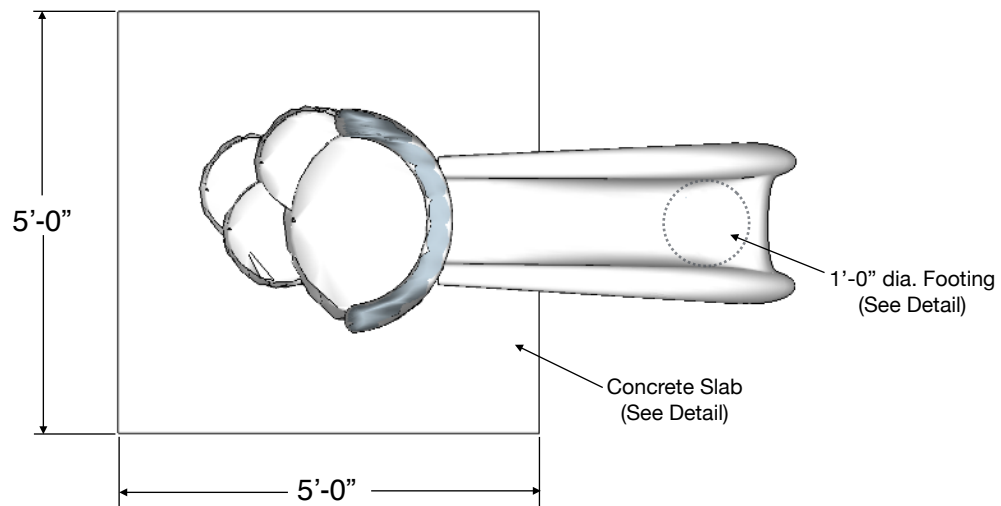
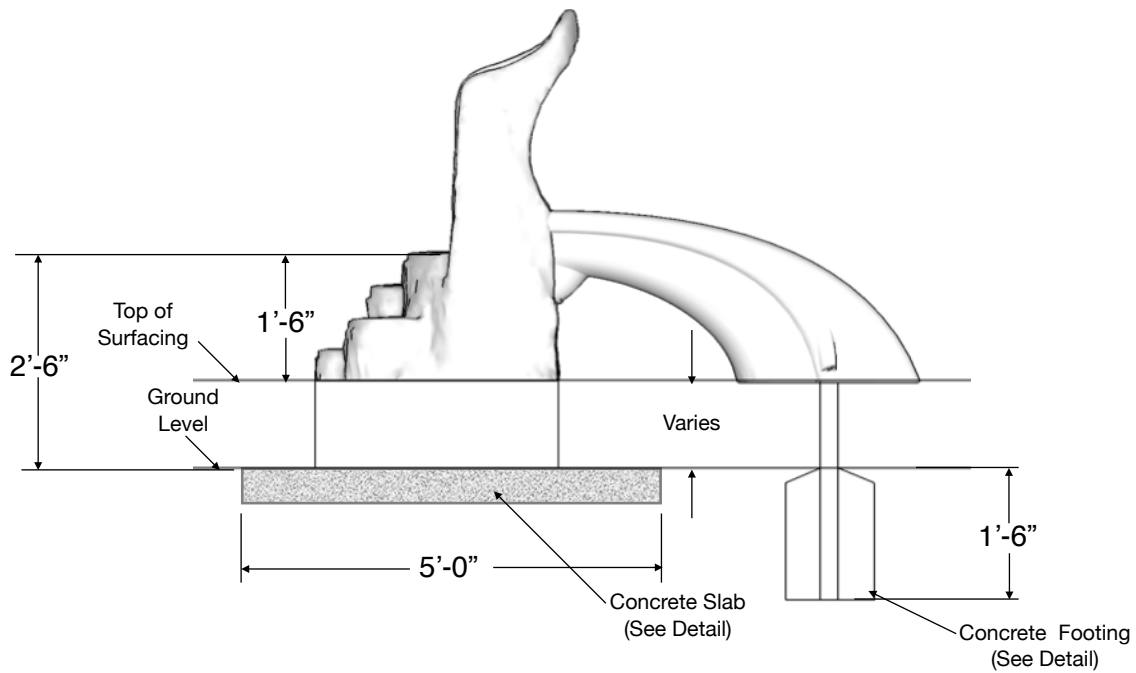

**Product: 1000226 - In-Ground**

**Surface Mount**

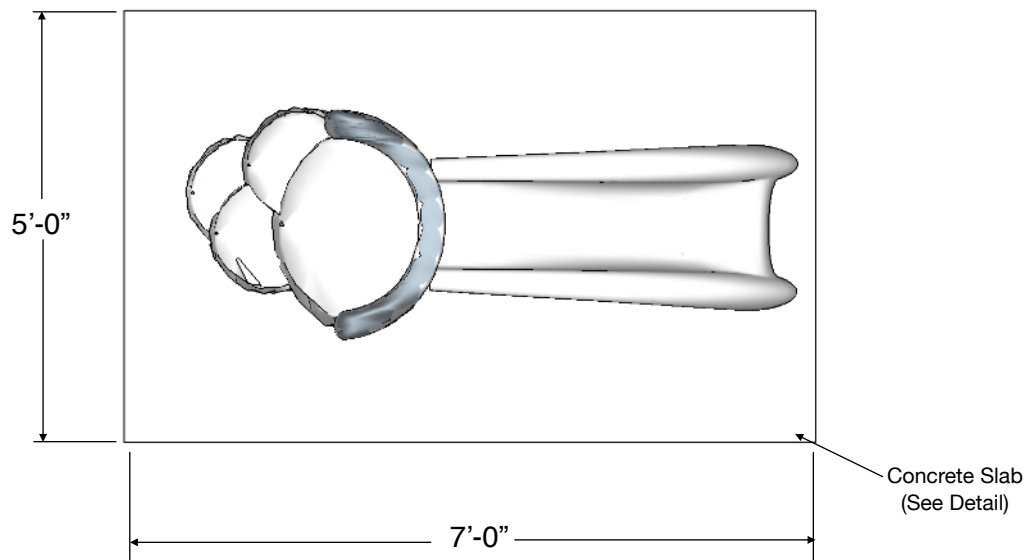
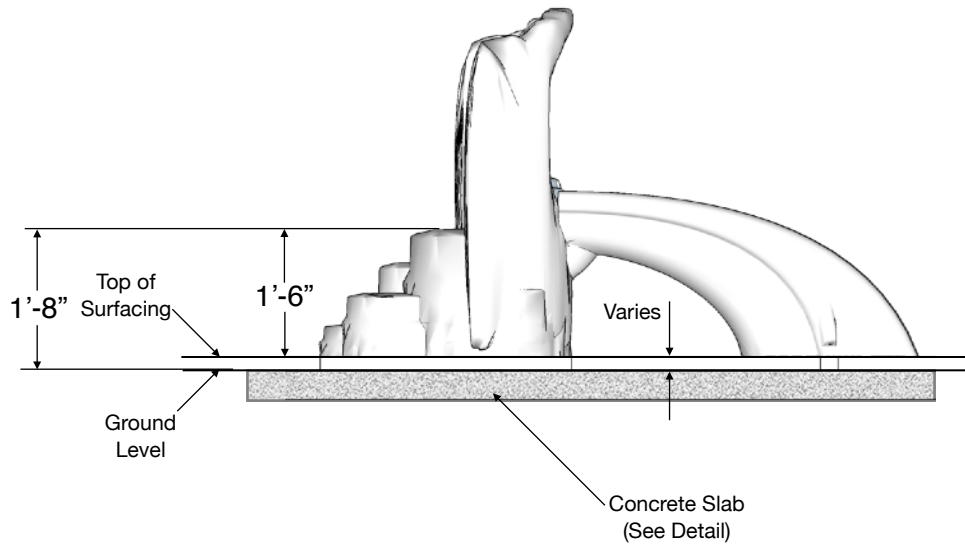

**Product: 1000226 - Surface Mount**

**NOTE: Read installation instructions thoroughly before starting installation process.**

**Step 1:** Lay out the area and prepare the site for install. Concrete must be installed over a solid, level base. Check local soil condition and codes. See installation instructions sheet for minimum use zone requirements to ensure proper spacing and adequate surfacing area.

**Step 2:** Pour a concrete base for the Oak Landing unit. Refer to the typical slab section on the typical footing page in these installation instructions. The concrete should be flush with the ground level. Allow time for the concrete to completely cure before continuing. For the in-ground installation, refer to the typical in-ground footing detail on excavating a hole for the the slide foot buck.

**NOTES PRIOR TO CONSTRUCTION:**

- Use appropriate equipment to lift and move the play equipment.
- Check local codes and requirements prior to digging or installing any equipment.

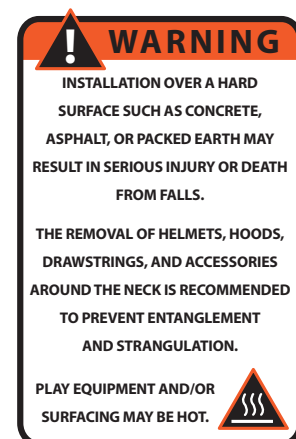

## Assembly Instructions

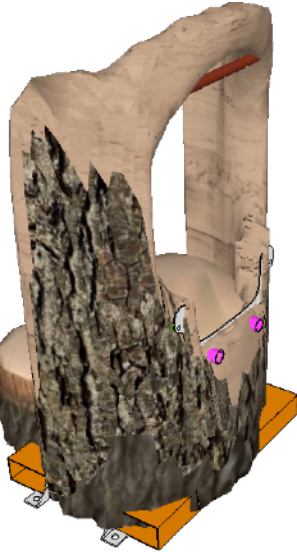

**STEP 3** - Locate and Place the Oak Landing unit in its final installation location..

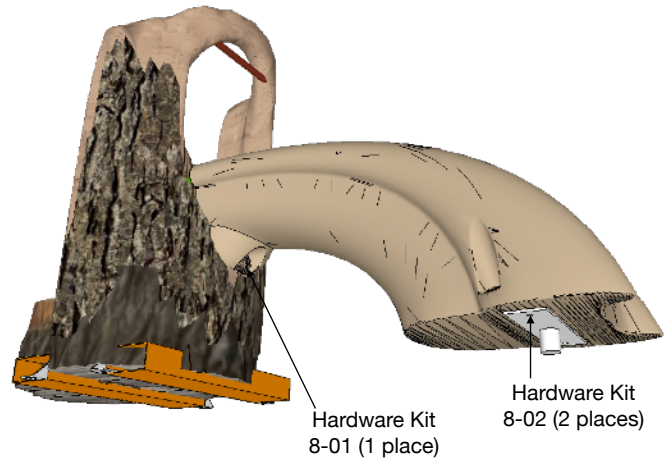

**Step 4:** Attach the slide foot back to the slide using hardware kit 8-02 (2 places).

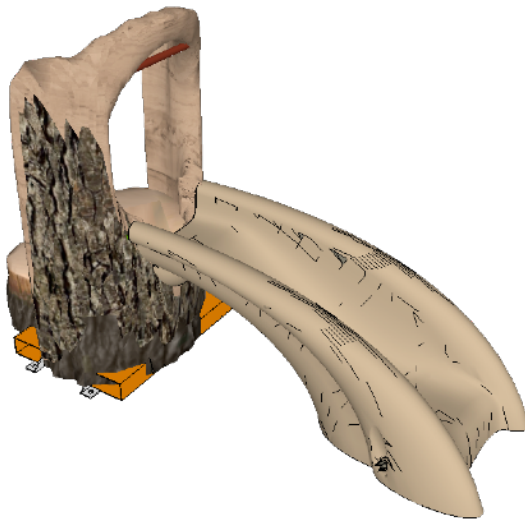

**Step 5:** Position the slide to the Oak Landing unit.

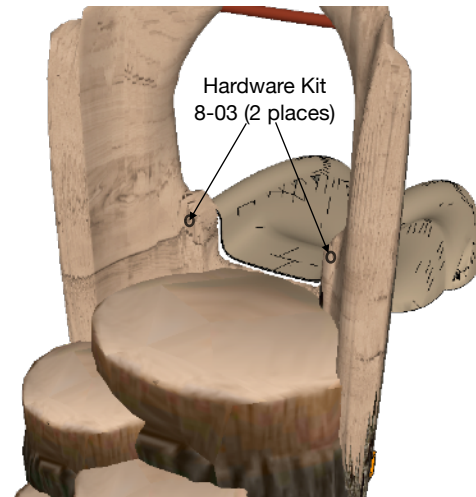

**Step 6:** Bolt the slide to the Oak Landing unit using hardware kit 8-01 (1 place) and hardware kit 8-03 (2 places).

~ All dimensions are approximate ~

**User Group Age: 2-5**

Last Revised 12/1/2021

**Step 7:** See the hardware recommendation page and locate your anchor bolts, supplied by Cre8Play. Using the proper standard drill bit size noted in the installation table, drill the concrete to the appropriate hole depth (C).

**Step 8:** Insert the anchor bolt into the hole and tighten until the bolt is fully seated. Do NOT over tighten the anchor bolts.

**Step 9:** Refer to the surfacing manufacturer for installation of an approved impact attenuating play surface with a minimum of 6 feet in every direction.

**Installation Table**

Anchor Bolt Size	ANSI Standard Drill Bit Diameter	Anchor Head (Socket Size) Diameter (A)	Minimum Embedment (B)	Hole Depth (C)
1/2" x 3"	7/16"	3/4"	2 1/2"	3 1/2"

**Anchor Bolt (Large Diameter Tapcon) Installation:**

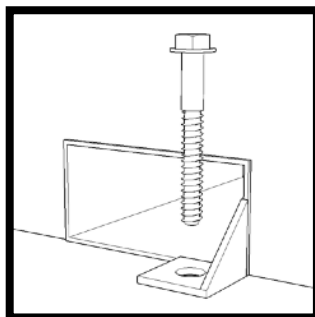

**Mounting Detail**  
(Not to Scale)

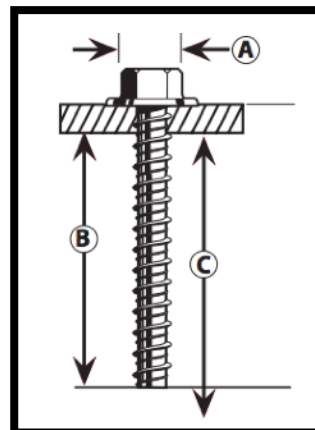

**Step 1: Drill**

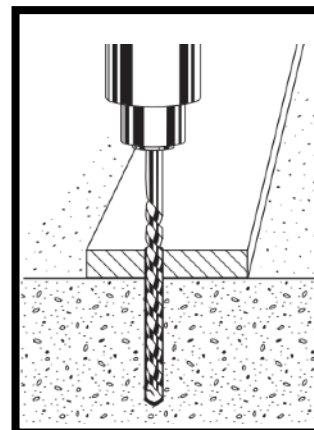

**Step 2: Anchor**

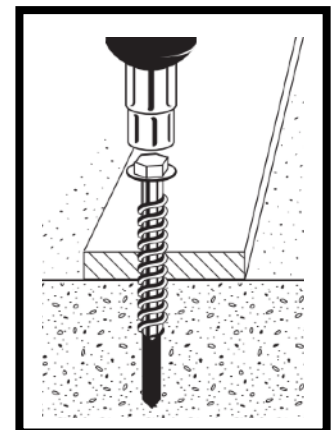

**HARDWARE KIT 8-01**

- 3/8" X 3" BUTTON HEAD, PIN-IN, SS BOLT X1
- 3/8" FLAT WASHER, SS X1
- 3/8" SPLIT LOCK WASHER, SS X1

**HARDWARE KIT 8-02**

- 3/8" X 1 1/4" BUTTON HEAD, PIN-IN, SS BOLT X2
- 3/8" FLAT WASHER, SS X2
- 3/8" SPLIT LOCK WASHER, SS X2

**HARDWARE KIT 8-03**

- 3/8" X 1 1/4" BUTTON HEAD, PIN-IN, SS BOLT X2
- 3/8" SPLIT LOCK WASHER, SS X2

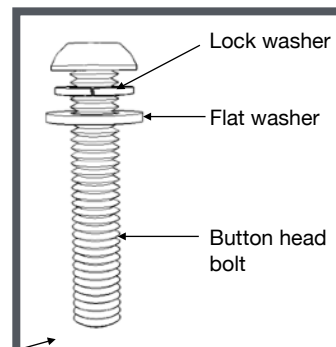

**Button head bolt, lock washer and flat washer**

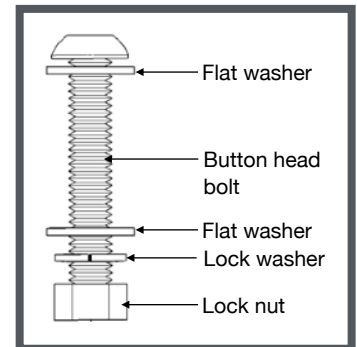

**Button head bolt, lock washer, flat washers and lock nut**

USE THREAD LOCKING COMPOUND ON ALL THREADED FASTENERS

~ All dimensions are approximate ~

**User Group Age: 2-5**

Last Revised 12/1/2021

5121 Winnetka Ave N • Suite 108

New Hope, MN 55428

612.670.8195

info@cre8play.com

cre8play.com

